

Collet Chucks for 5C / 16C / 3J Collets



5W & 16W Wide Opening Collet Chucks



5C-ND Dead Length Collet Chucks



Chuck Features

- Dead length design with reduced nose for full size machines and sub spindles
- All components are hardened alloy steel precision ground for accuracy and long term performance.
- Internal components are sealed to prevent chip accumulation inside chuck body
- Modular chuck design can be adapted to any machine spindle and draw tube configuration
- Call for spindle mountings not listed

Specifications & Dimensions

Chuck Model	Collet Model	Spindle Nose	Max Speed	Through Capacity	Draw Tube Stroke	Max Draw Tube Force	Chuck Weight
CB5C-ND/A5	5C	A2-5	6,000 rpm	1.062" 27mm	.078" 2.0mm	3,200 lbs 1,422 kg	15.1 lb 6.7 kg
CB5C-ND/A6	5C	A2-6	6,000 rpm	1.062" 27mm	.078" 2.0mm	3,200 lbs 1,422 kg	15.3 lb 6.8 kg
CB5C-ND/8	5C	A2-8	6,000 rpm	1.062" 27mm	.078" 2.0mm	3,200 lbs 1,422 kg	23.5 lb 10.4 kg
CB5C-ND/140	5C	140mm	6,000 rpm	1.062" 27mm	.078" 2.0mm	3,200 lbs 1,422 kg	15.1 lb 6.7 kg

Chuck Model	A	B	C
CB5C-ND/A5	5.700" (144.8mm)	5.740" (145.8mm)	1.100" (27.9mm)
CB5C-ND/A6	6.480" (164.6mm)	5.640" (143.3mm)	1.000" (31.4mm)
CB5C-ND/A8	7.950" (201.9mm)	6.260" (159mm)	1.620" (41.1mm)
CB5C-ND/140	5.700" (144.8mm)	5.740" (145.8mm)	1.100" (27.9mm)

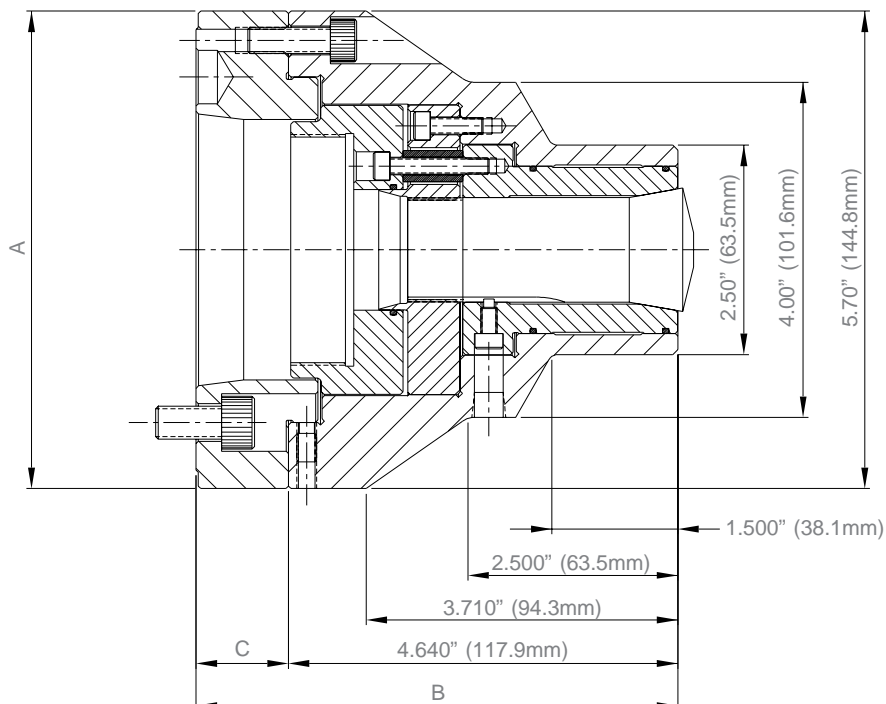

5C-D Dead Length Collet Chucks



Chuck Features

- Dead length design with reduced diameter mounting for smaller machines and rotary tables
- All components are hardened alloy steel precision ground for accuracy and long term performance
- Internal components are sealed to prevent chip accumulation inside chuck body
- Modular chuck design can be adapted to any machine spindle and draw tube configuration
- Call for spindle mountings not listed

Specifications & Dimensions

Chuck Model	Collet Model	Spindle Nose	Max Speed	Through Capacity	Draw Tube Stroke	Max Draw Tube Force	Chuck Weight
CB5C-D/A4	5C	A2-4	6,000 rpm	1.062" 27mm	.078" 2.0mm	3,200 lbs 1,422 kg	8.9 lb 4 kg
CB5C-D/A5	5C	A2-5	6,000 rpm	1.062" 27mm	.078" 2.0mm	3,200 lbs 1,422 kg	10.0 lb 4.4 kg
CB5C-D/85	5C	85mm	6,000 rpm	1.062" 27mm	.078" 2.0mm	3,200 lbs 1,422 kg	7.9 lb 3.5 kg
CB5C-D/110	5C	110mm	6,000 rpm	1.062" 27mm	.078" 2.0mm	3,200 lbs 1,422 kg	8.9 lb 4 kg
CB5C-ND/140	5C	140mm	6,000 rpm	1.062" 27mm	.078" 2.0mm	3,200 lbs 1,422 kg	10.0 lb 4.4 kg

Chuck Model	A	B	C
CB5C-D/A4	4.330" (110mm)	4.620" (117.3mm)	.938" (23.8mm)
CB5C-D/A5	5.250" (133.4mm)	4.920" (125mm)	1.238" (31.4mm)
CB5C-D/85	4.330" (110mm)	4.250" (108mm)	.568" (14.4mm)
CB5C-D/110	4.330" (110mm)	4.620" (117.3mm)	.938" (23.8mm)
CB5C-ND/140	5.250" (133.4mm)	4.920" (125mm)	1.238" (31.4mm)

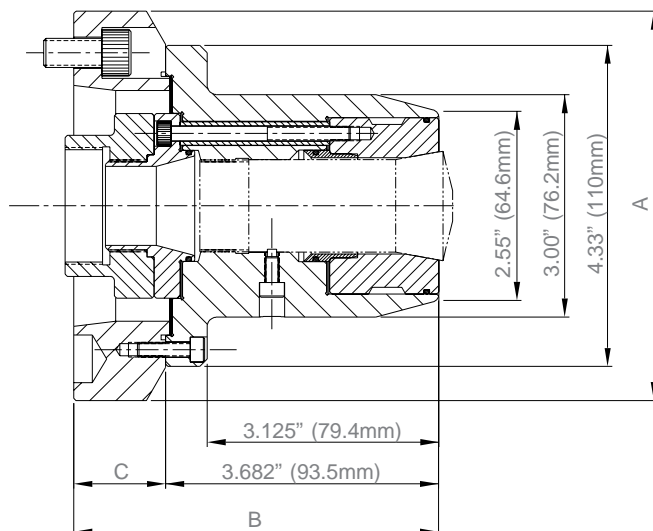

16C Dead Length Collet Chucks



Chuck Features

- Dead length design with reduced nose
- All components are hardened alloy steel precision ground for accuracy and long term performance.
- Internal components are sealed to prevent chip accumulation inside chuck body.
- Modular chuck design can be adapted to any machine spindle and draw tube configuration.
- Call for spindle mountings not listed.

Specifications & Dimensions

Chuck Model	Collet Model	Spindle Nose	Max Speed	Through Capacity	Draw Tube Stroke	Max Draw Tube Force	Chuck Weight
CB16C-ND/A5	16C	A2-5	6,000 rpm	1.625" 41.2mm	.078" 2.0mm	5,400 lbs 2,450 kg	29.0 lb 12.9 kg
CB16C-ND/A6	16C	A2-6	6,000 rpm	1.625" 41.2mm	.078" 2.0mm	5,400 lbs 2,450 kg	30.2 lb 13.4 kg
CB16C-ND/A8	16C	A2-8	6,000 rpm	1.625" 41.2mm	.078" 2.0mm	5,400 lbs 2,450 kg	36.7 lb 16.3 kg
CB16C-ND/140	16C	140mm	6,000 rpm	1.625" 41.2mm	.078" 2.0mm	5,400 lbs 2,450 kg	29.0 lb 12.9 kg

Chuck Model	A	B	C
CB16C-ND/A5	6.480" (164.6mm)	5.950" (151.1mm)	.800" (27.9mm)
CB16C-ND/A6	6.480" (164.6mm)	6.500" (165.1mm)	1.350" (31.4mm)
CB16C-ND/A8	8.250" (209.6mm)	6.775" (172.1mm)	1.625" (41.3mm)
CB16C-ND/140	6.480" (164.6mm)	5.950" (151.1mm)	.800" (27.9mm)

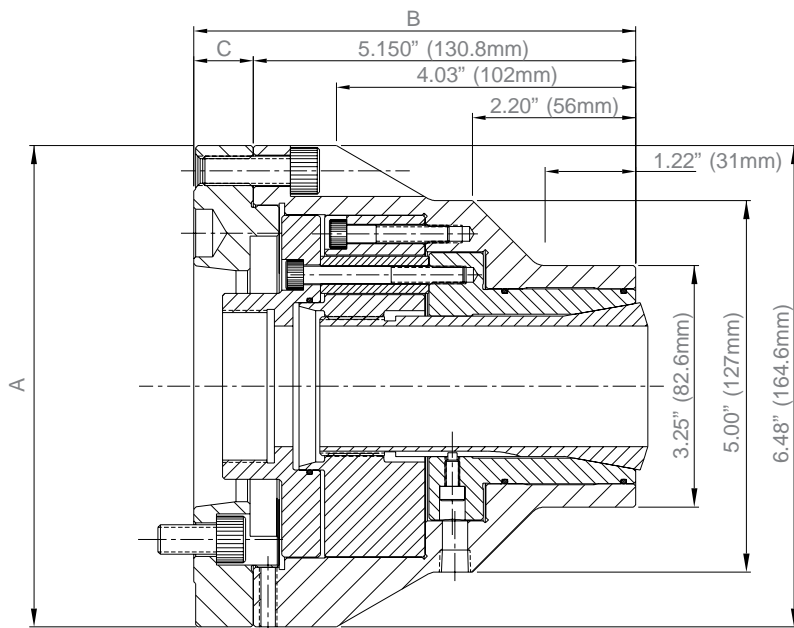

3J Dead Length Collet Chucks



Chuck Features

- Dead length design with reduced nose
- All components are hardened alloy steel precision ground for accuracy and long term performance.
- Internal components are sealed to prevent chip accumulation inside chuck body.
- Modular chuck design can be adapted to any machine spindle and draw tube configuration.
- Call for spindle mountings not listed.

Specifications & Dimensions

Chuck Model	Collet Model	Spindle Nose	Max Speed	Through Capacity	Draw Tube Stroke	Max Draw Tube Force	Chuck Weight
CB3J-ND/A5	3J	A2-5	6,000 rpm	1.750" 44.4mm	.078" 2.0mm	5,400 lbs 2,450 kg	28.8 lb 12.8 kg
CB3J-ND/A6	3J	A2-6	6,000 rpm	1.750" 44.4mm	.078" 2.0mm	5,400 lbs 2,450 kg	30.0 lb 13.3 kg
CB3J-ND/A8	3J	A2-8	6,000 rpm	1.750" 44.4mm	.078" 2.0mm	5,400 lbs 2,450 kg	36.5 lb 16.2 kg
CB3J-ND/140	3J	140mm	6,000 rpm	1.750" 44.4mm	.078" 2.0mm	5,400 lbs 2,450 kg	28.8 lb 12.8 kg

Chuck Model	A	B	C
CB3J-ND/A5	6.480" (164.6mm)	5.950" (151.1mm)	.800" (27.9mm)
CB3J-ND/A6	6.480" (164.6mm)	6.500" (165.1mm)	1.350" (31.4mm)
CB3J-ND/A8	8.250" (209.6mm)	6.775" (172.1mm)	1.625" (41.3mm)
CB3J-ND/140	6.480" (164.6mm)	5.950" (151.1mm)	.800" (27.9mm)

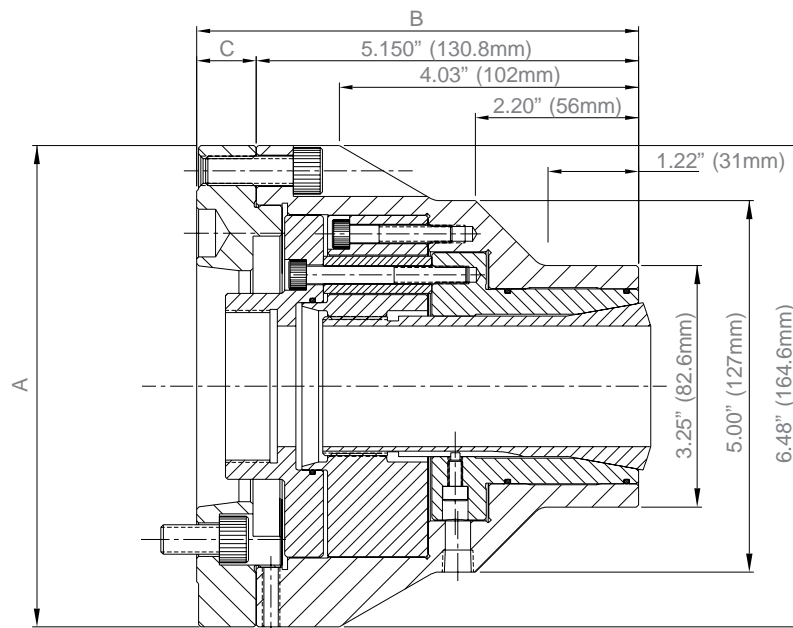

5W & 16W Wide Opening Collet Chucks



Collet & Chuck Features

- 5W and 16W wide opening collets are designed to grip over the shoulder of headed parts
- Collets open up to .394" (10mm) above the nominal clamping diameter
- Six segmented double angle design collet with ID thread for mounting part stops or ejectors
- Dead length chuck design
- Chuck components are hardened alloy steel precision ground for accuracy and long term performance
- Internal components are sealed to prevent chip accumulation inside chuck body
- Modular chuck design can be adapted to any machine spindle and draw tube configuration.
- Call for spindle mountings not listed

Chuck Specifications

Chuck Model	Collet Model	Spindle Nose	Max Speed	Through Capacity	Draw Tube Stroke	Max Draw Tube Force	Chuck Weight
CB5W-D/A4	5W	A2-4	6,000 rpm	1.062" 27mm	.370" 9.4mm	3,200 lbs 12422 kg	13.4 lb 6 kg
CB5W-D/A5	5W	A2-5	6,000 rpm	1.062" 27mm	.370" 9.4mm	3,200 lbs 12422 kg	14.6 lb 6.5 kg
CB5W-D/140	5W	140mm	6,000 rpm	1.062" 27mm	.370" 9.4mm	3,200 lbs 12422 kg	14.6 lb 6.5 kg
CB16W-D/A5	16W	A2-5	6,000 rpm	1.625" 41.2mm	.370" 9.4mm	5,400 lbs 2,450 kg	40.6 lb 18 kg
CB16W-D/A6	16W	A2-6	6,000 rpm	1.625" 41.2mm	.370" 9.4mm	5,400 lbs 2,450 kg	43.7 lb 19.4 kg
CB16W-D/140	16W	140mm	6,000 rpm	1.625" 41.2mm	.370" 9.4mm	5,400 lbs 2,450 kg	40.6 lb 18 kg



5W & 16W Collets

5W & 16W collets are a six segmented design. Available exclusively from MicroCentric, 5W & 16W collets are made to order for specific applications. The following information must be provided when ordering 5W or 16W collets.

- N** Nominal Clamping Diameter
- W** Opening Diameter
- L** Land Length
- R** Relief Diameter

Chuck Dimensions

Chuck Model	A	B	C	D	E	F	G
CB5W-D/A4	1.875" 47.6mm	3.375" 85.7mm	4.330" 110mm	4.330" 110mm	6.120" 155.4mm	5.182" 131.6mm	.938" 23.8mm
CB5W-D/A5	1.875" 47.6mm	3.375" 85.7mm	4.33" 110mm	5.25" 133.4mm	6.120" 155.4mm	5.182" 131.6mm	.938" 23.8mm
CB5W-D/140	1.875" 47.6mm	3.375" 85.7mm	4.33" 110mm	5.25" 133.4mm	6.120" 155.4mm	5.182" 131.6mm	.938" 23.8mm
CB16W-D/A5	2.910" 73.9mm	5.000" 127mm	6.480" 164.6mm	6.480" 164.6mm	8.860" 239mm	8.060" 204.7mm	.800" 20.3mm
CB16W-D/A6	2.910" 73.9mm	5.000" 127mm	6.480" 164.6mm	6.480" 164.6mm	9.410" 239mm	8.060" 204.7mm	1.350" 34.3mm
CB16W-D/140	2.910" 73.9mm	5.000" 127mm	6.480" 164.6mm	6.480" 164.6mm	8.860" 239mm	8.060" 204.7mm	.800" 20.3mm

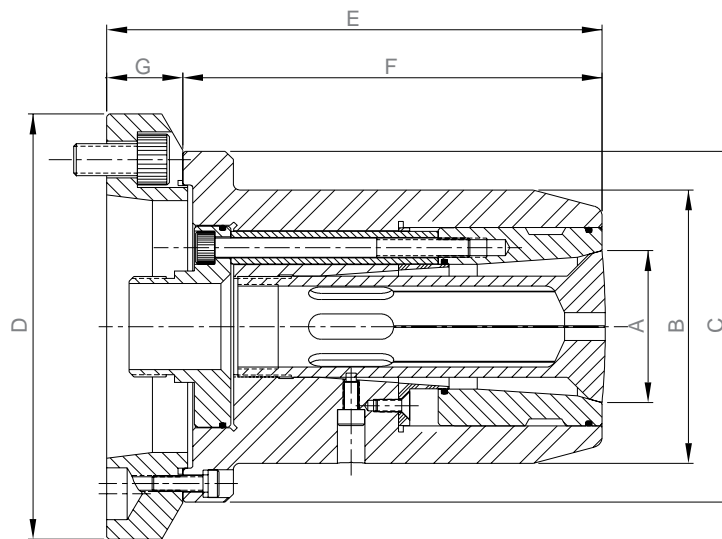

Collet Dimensions

Collet Model	A	B	C	D	E	F	G
5W	1.875" 47.6mm	1.250" 31.75mm	.430" 10.9mm	.039" 1mm	4.500" 114.3mm	1.238"-20 RH	1.041"-24 RH
16W	2.910" 73.9mm	1.889" 47.9mm	.675" 17.1mm	.100" 2.5mm	6.000" 152.4mm	1.820" x 1.75mm RH	1.687"-20 RH

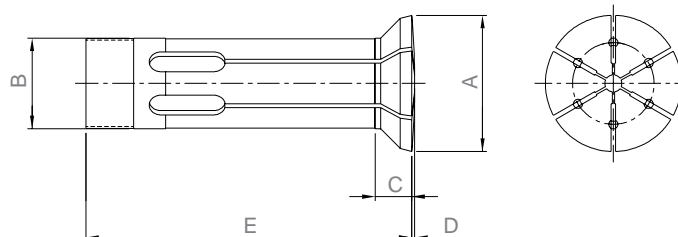
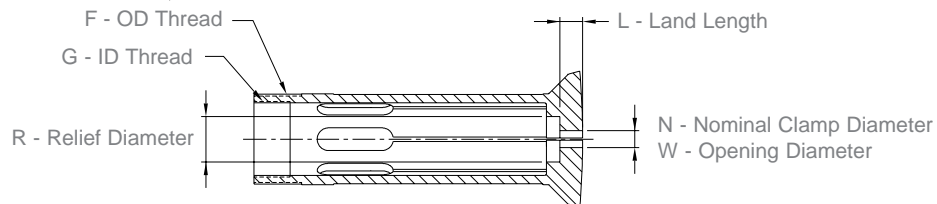



MicroCentric Corp • 25 So. Terminal Drive, Plainview, NY 11803 • USA
Tel: 516-349-7220 • Fax: 516-349-9354 • e-mail: sales@MicroCentric.com

1-800-573-1139
www.MicroCentric.com