

PPC Series Precision Power Chucks



The World's Most Accurate Power Chuck

Improve productivity and lower costs by enhancing workpiece quality

through accurate and repeatable workholding. Manufacturers that are able to maintain close concentricity across a workpiece's operation sequence benefit from lower scrap rates, reduced cycle times, and increased production capacity. By holding close tolerances and minimizing the amount of material left for finishing operations, you not only reduce your cost per part, but you end up with more parts produced at the end of each shift. The accuracy of MicroCentric PPC Series Chucks also provides the capability to improve parallelism, roundness, and squareness, as well as holding closer size tolerances.

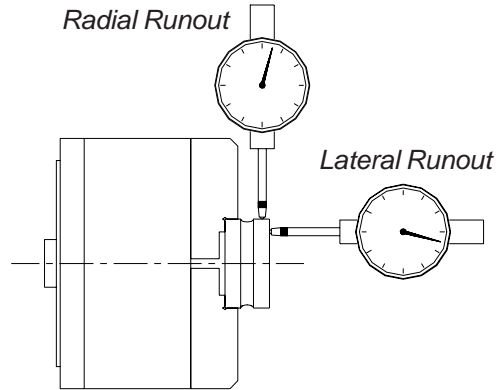

Accuracy to 0.0001" TIR

Standard repeating accuracy of PPC chucks is .0001" (0.0025mm) TIR maximum radial and lateral runout.

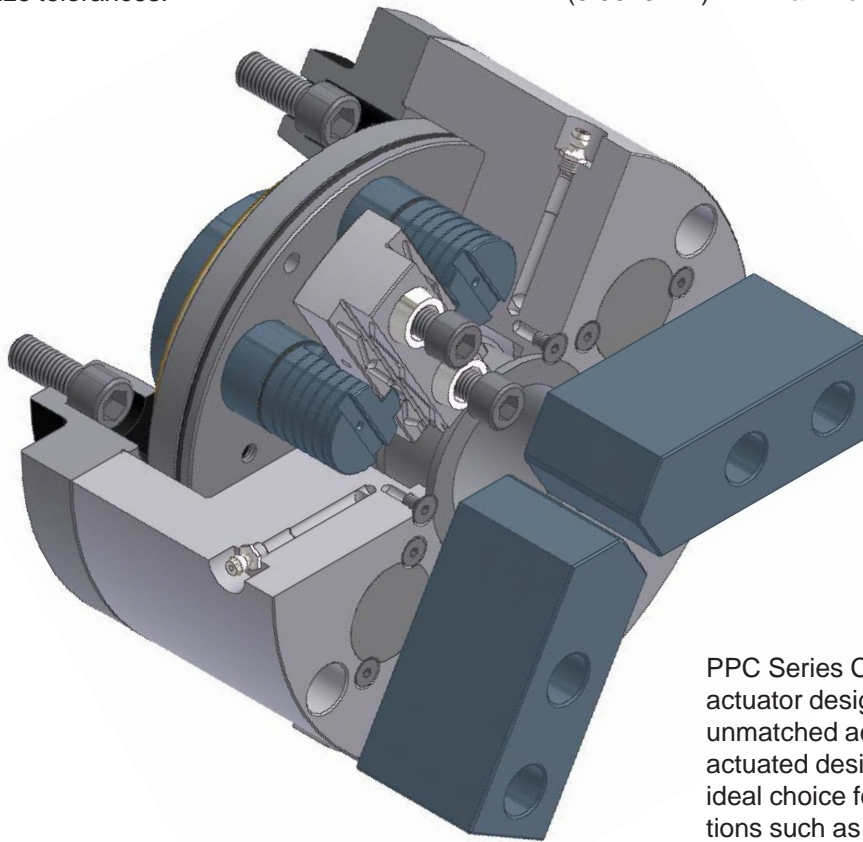

PPC Series Chucks feature a dual actuator design for superior rigidity and unmatched accuracy in a draw tube actuated design. PPC chucks are the ideal choice for precision finishing operations such as hard turning, sub spindles, and grinding.



QC Precision Change Jaw Locating System

Patented precision change jaw locating system reduces setup time by maintaining .0002" (0.005mm) runout after changing top jaws. MicroCentric's QC system saves valuable set up time up by eliminating the remachining of top jaws or indicating in the chuck in order to maintain close workpiece concentricity. PPC chucks are qualified so jaws can be changed between chucks and maintain .0008" (0.02mm) TIR runout.

QC System Accuracies

- .0002" (0.005mm) TIR max runout when top jaws finished and replaced on same chuck
- .0008" (.02mm) TIR max runout when top jaws finished on another QC chuck (same model)

QC System Design

QC top jaws are located by two tapered buttons mounted in the master jaw. QC top jaws feature precision finished taper seats that are located by the tapered buttons. QC top jaws seat on the OD of the tapered buttons and the face of the master jaw, assuring high accuracy and rigidity.

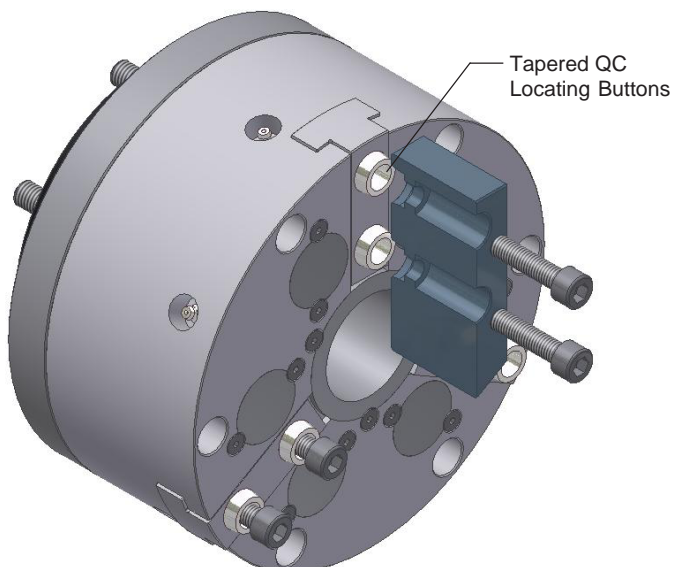

PPC110D Models



Features

- 4.33" (110mm) chuck diameter
- 3 jaw and 2 jaw models
- QC precision change jaw system and dowel pin located models
- Standard and long stroke models
- 1.063" (27mm) through hole
- Precision fit master jaws to minimize jaw lift
- Hardened chuck body, actuators, and master jaws, for long term accuracy and performance

Repeating Accuracy

- .0001" (0.0025mm) TIR

PPC110D Specifications

Chuck Model	PPC110D-3/QC	PPC110D-2/QC	PPC110D-3/DP	PPC110D-2/DP	PPC110DL-3/QC	PPC110DL-3/DP
Accuracy ¹	.0001" 0.0025mm	.0001" 0.0025mm	.0001" 0.0025mm	.0001" 0.0025mm	.0001" 0.0025mm	.0001" 0.0025mm
Number of Jaws	3	2	3	2	3	3
Through Hole	1.063" 27mm	1.063" 27mm	1.063" 27mm	1.063" 27mm	1.063" 27mm	1.063" 27mm
Jaw Stroke ²	.120" 3.0mm	.120" 3.0mm	.120" 3.0mm	.120" 3.0mm	.180" 4.6mm	.180" 4.6mm
Actuator Stroke	.340" 8.6mm	.340" 8.6mm	.340" 8.6mm	.340" 8.6mm	.340" 8.6mm	.340" 8.6mm
Max Draw Bar Force	2,090 lbs 9.3 kN	1,390 lbs 6.2 kN	2,090 lbs 9.3 kN	1,390 lbs 6.2 kN	2,090 lbs 9.3 kN	2,090 lbs 9.3 kN
Min Draw Bar Force	250 lbs 1.1 kN	250 lbs 1.1 kN	250 lbs 1.1 kN	250 lbs 1.1 kN	250 lbs 1.1 kN	250 lbs 1.1 kN
Max Clamping Force ³	4,600 lbs 20.5 kN	3,065 lbs 13.6 kN	4,600 lbs 20.5 kN	3,065 lbs 13.6 kN	3,760 lbs 16.7 kN	3,760 lbs 16.7 kN
Max Speed ⁴	6,000 rpm	6,000 rpm	6,000 rpm	6,000 rpm	5,000 rpm	5,000 rpm
Chuck Weight ⁵	7.0 lbs 3.2 kg	7.0 lbs 3.2 kg	7.0 lbs 3.2 kg	7.0 lbs 3.2 kg	7.0 lbs 3.2 kg	7.0 lbs 3.2 kg
Moment of Inertia ⁵	.13 lb-ft ² 0.005 kg-m ²	.13 lb-ft ² 0.005 kg-m ²	.13 lb-ft ² 0.005 kg-m ²	.13 lb-ft ² 0.005 kg-m ²	.13 lb-ft ² 0.005 kg-m ²	.13 lb-ft ² 0.005 kg-m ²

1 - Accuracy is the total indicator reading (radial and lateral runout) of a master gage measured 1.00" (25.4mm) from the top face of the standard top jaw at 1/2 max draw tube force.

2 - Total jaw stroke.

3 - Total clamping force.

4 - Maximum speed with standard top jaw at max draw tube force.

5 - Without top jaws and spindle mounting plate.

Standard Accessories

- Blank draw tube adapter
- Blank top jaws, chuck lubricant, and grease guns are sold separately. See pages 13 and 14 for available accessories.

Threaded Draw Tube Adapters & Spindle Mounting Plates

- Threaded draw tube adapters are furnished on request
- A2-4, A2-5, and various flat, threaded, and tapered nose spindle mounting plates are available on request.

PPC110D/QC Dimensions

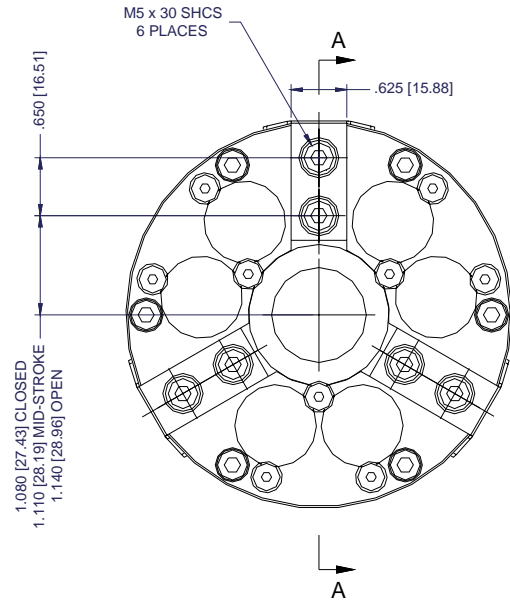
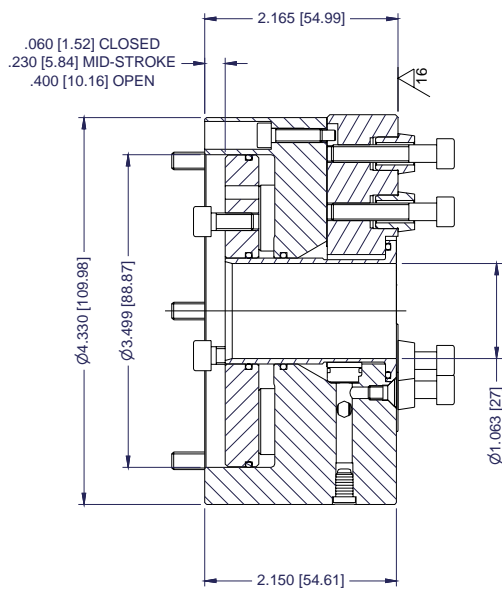

PPC110D/DP Dimensions

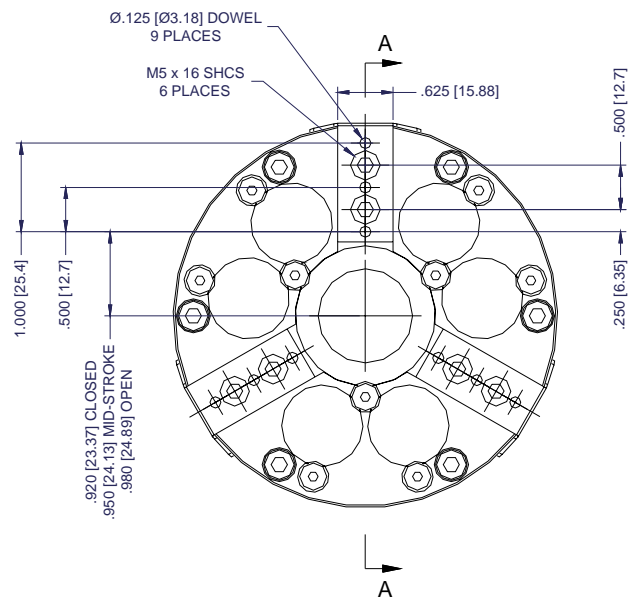
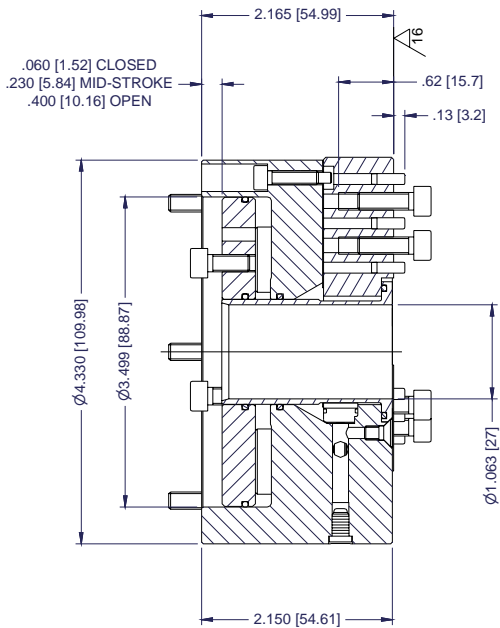

PPC165D Models



Features

- 6.45" (165mm) chuck diameter
- 3 jaw and 2 jaw models
- QC precision change jaw system
- Standard and long stroke models
- 1.375" (35mm) through hole
- Precision fit master jaws to minimize jaw lift
- Hardened chuck body, actuators, and master jaws, for long term accuracy and performance

Repeating Accuracy

- .0001" (0.0025mm) TIR

PPC165D Specifications

Chuck Model	PPC165D-3/QC	PPC165D-2/QC	PPC165DL-3/QC	PPC165DL-2/QC
Accuracy ¹	.0001" 0.0025mm	.0001" 0.0025mm	.0001" 0.0025mm	.0001" 0.0025mm
Number of Jaws	3	2	3	2
Through Hole	1.375" 35mm	1.375" 35mm	1.375" 35mm	1.375" 35mm
Jaw Stroke ²	.180" 3.0mm	.180" 3.0mm	.270" 6.9mm	.270" 6.9mm
Actuator Stroke	.510" 13.0mm	.510" 13.0mm	.510" 13.0mm	.510" 13.0mm
Max Draw Bar Force	3,640 lbs 16.2 kN	2,425 lbs 10.8 kN	3,640 lbs 16.2 kN	2,425 lbs 10.8 kN
Min Draw Bar Force	350 lbs 1.5 kN	350 lbs 1.5 kN	350 lbs 1.5 kN	350 lbs 1.5 kN
Max Clamping Force ³	8,370 lbs 37.2 kN	5,330 lbs 23.7 kN	6,840 lbs 30.4 kN	4,515 lbs 20.1 kN
Max Speed ⁴	5,000 rpm	5,000 rpm	4,000 rpm	4,000 rpm
Chuck Weight ⁵	25.2 lbs 11.4 kg	25.2 lbs 11.4 kg	25.2 lbs 11.4 kg	25.2 lbs 11.4 kg
Moment of Inertia ⁵	.99 lb-ft ² 0.04 kg-m ²	.99 lb-ft ² 0.04 kg-m ²	.99 lb-ft ² 0.04 kg-m ²	.99 lb-ft ² 0.04 kg-m ²

1 - Accuracy is the total indicator reading (radial and lateral runout) of a master gage measured 1.00" (25.4mm) from the top face of the standard top jaw at 1/2 max draw tube force.

2 - Total jaw stroke.

3 - Total clamping force.

4 - Maximum speed with standard top jaw at max draw tube force.

5 - Without top jaws and spindle mounting plate.

Standard Accessories

- Blank draw tube adapter
- Blank top jaws, chuck lubricant, and grease guns are sold separately. See pages 13 and 14 for available accessories.

Threaded Draw Tube Adapters & Spindle Mounting Plates

- Threaded draw tube adapters are furnished on request
- A2-5, 140mm flat nose as well as other spindle mounting plates are available on request.

PPC165D/QC Dimensions

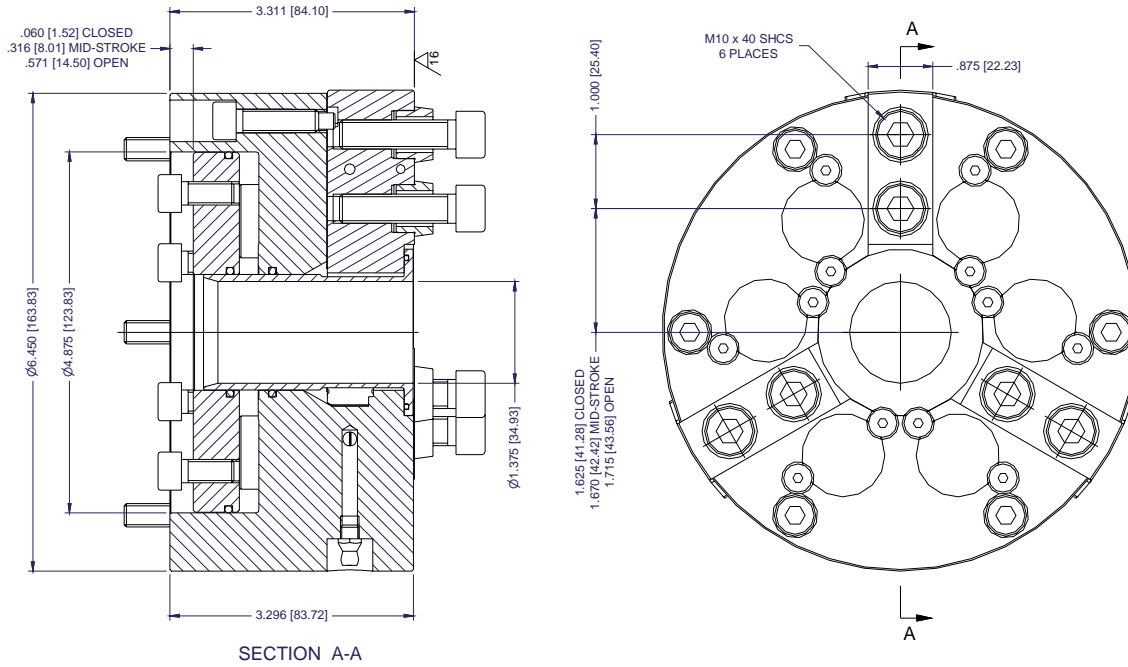

PPC165D/QC/A5 Dimensions

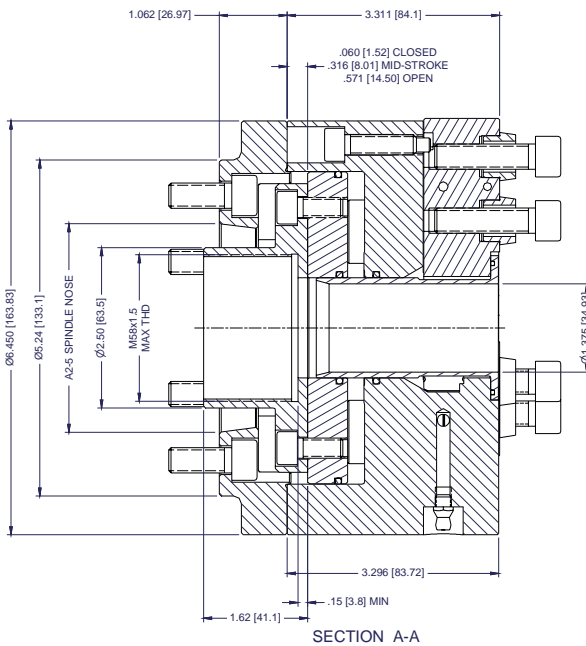

PPC165D/QC/140 Dimensions

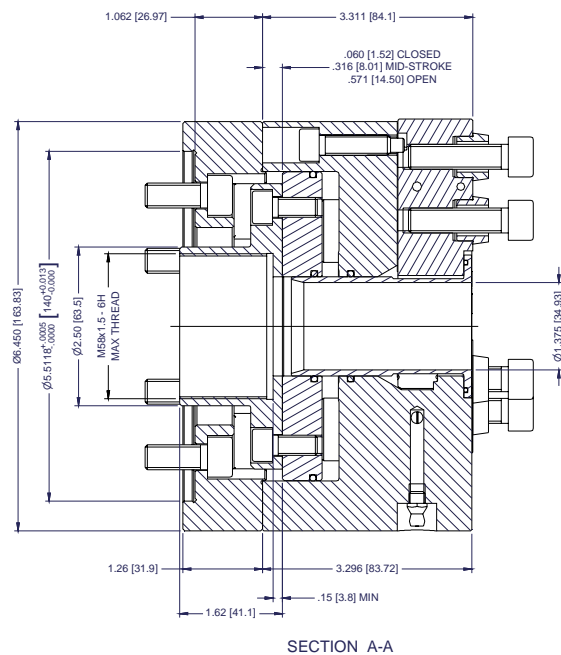

PPC210D Models



Features

- 8.25" (210mm) chuck diameter
- 3 jaw and 2 jaw models
- QC precision change jaw system
- Standard and long stroke models
- 2.050" (52mm) through hole
- Precision fit master jaws to minimize jaw lift
- Hardened chuck body, actuators, and master jaws, for long term accuracy and performance

Repeating Accuracy

- .0001" (0.0025mm) TIR

PPC210D Specifications

Chuck Model	PPC210D-3/QC	PPC210D-2/QC	PPC210DL-3/QC	PPC210DL-2/QC
Accuracy ¹	.0001" 0.0025mm	.0001" 0.0025mm	.0001" 0.0025mm	.0001" 0.0025mm
Number of Jaws	3	2	3	2
Through Hole	2.050" 52mm	2.050" 52mm	2.050" 52mm	2.050" 52mm
Jaw Stroke ²	.220" 5.6mm	.220" 5.6mm	.340" 8.6mm	.340" 8.6mm
Actuator Stroke	.630" 16.0mm	.630" 16.0mm	.630" 16.0mm	.630" 16.0mm
Max Draw Bar Force	5,840 lbs 26.0 kN	3,890 lbs 17.3 kN	5,840 lbs 26.0 kN	3,890 lbs 17.3 kN
Min Draw Bar Force	500 lbs 2.2 kN	500 lbs 2.2 kN	500 lbs 2.2 kN	500 lbs 2.2 kN
Max Clamping Force ³	13,430 lbs 59.7 kN	8,950 lbs 39.8 kN	10,510 lbs 46.8 kN	7,000 lbs 31.1 kN
Max Speed ⁴	4,500 rpm	4,500 rpm	3,500 rpm	3,500 rpm
Chuck Weight ⁵	44.3 lbs 20.1 kg	44.3 lbs 20.1 kg	44.3 lbs 20.1 kg	44.3 lbs 20.1 kg
Moment of Inertia ⁵	2.87 lb-ft ² 0.12 kg-m ²	2.87 lb-ft ² 0.12 kg-m ²	2.87 lb-ft ² 0.12 kg-m ²	2.87 lb-ft ² 0.12 kg-m ²

1 - Accuracy is the total indicator reading (radial and lateral runout) of a master gage measured 1.00" (25.4mm) from the top face of the standard top jaw at 1/2 max draw tube force.

2 - Total jaw stroke.

3 - Total clamping force.

4 - Maximum speed with standard top jaw at max draw tube force.

5 - Without top jaws and spindle mounting plate.

Standard Accessories

- Blank draw tube adapter
- Blank top jaws, chuck lubricant, and grease guns are sold separately. See pages 13 and 14 for available accessories.

Threaded Draw Tube Adapters & Spindle Mounting Plates

- Threaded draw tube adapters are furnished on request
- A2-6, A2-5 as well as other spindle mounting plates are available on request.

PPC210D/QC Dimensions

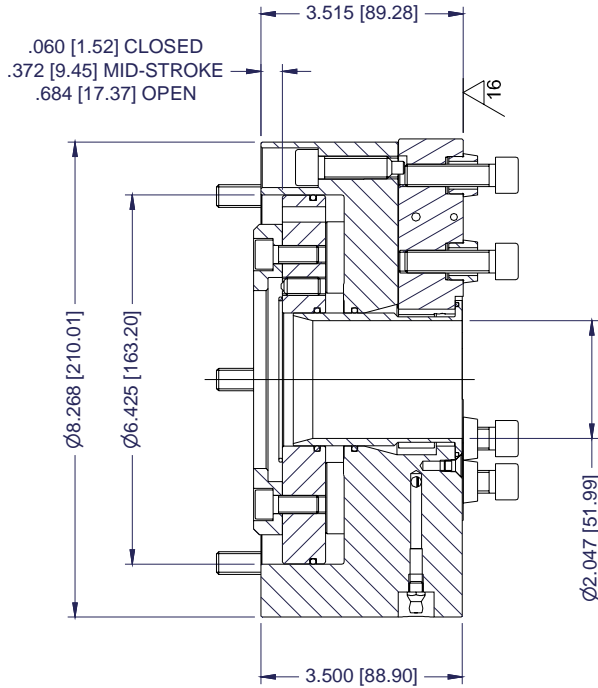

SECTION A-A

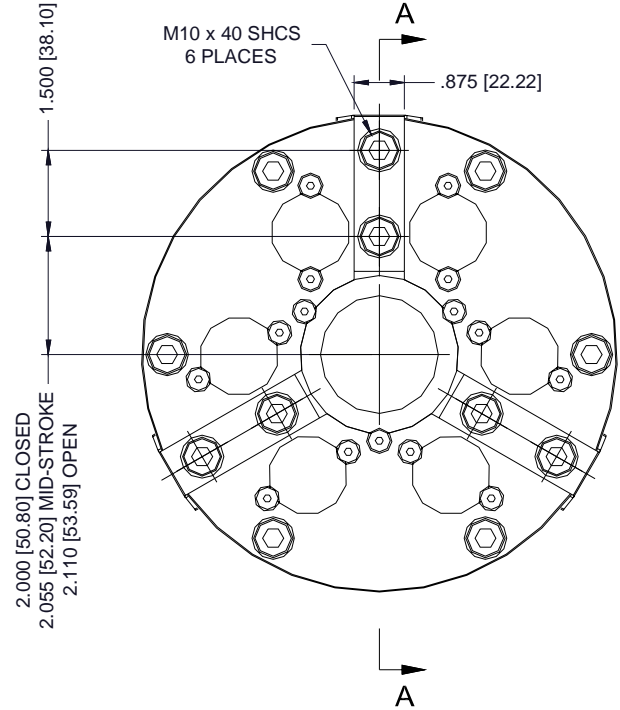

PPC210D/QC/A6 Dimensions

PPC210D/QC/A5 Dimensions

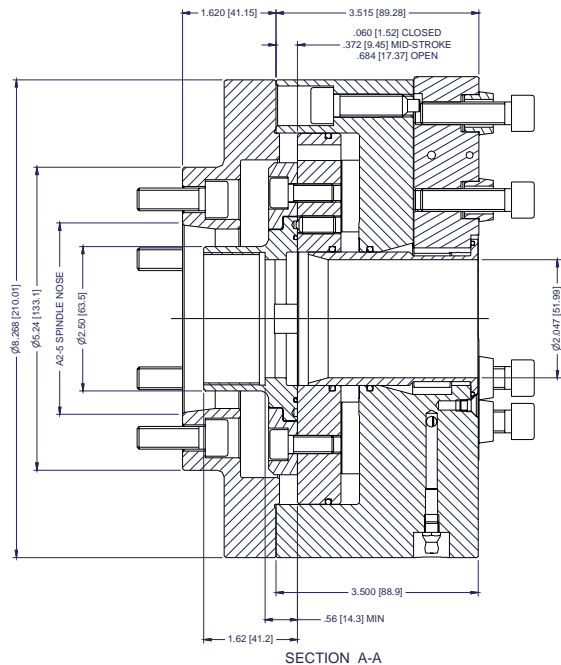
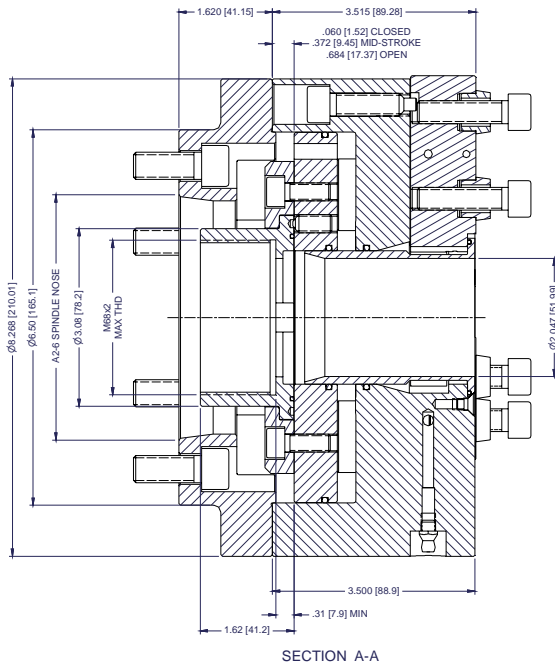

PPC250D Models



Features

- 10.00" (250mm) chuck diameter
- 3 jaw and 2 jaw models
- QC precision change jaw system
- Standard and long stroke models
- 2.60" (66mm) through hole
- Precision fit master jaws to minimize jaw lift
- Hardened chuck body, actuators, and master jaws, for long term accuracy and performance

Repeating Accuracy

- .0002" (0.005mm) TIR

PPC250D Specifications

Chuck Model	PPC250D-3/QC	PPC250D-2/QC	PPC250DL-3/QC	PPC250DL-2/QC
Accuracy ¹	.0002" 0.005mm	.0002" 0.005mm	.0002" 0.005mm	.0002" 0.005mm
Number of Jaws	3	2	3	2
Through Hole	2.600" 66mm	2.600" 66mm	2.600" 66mm	2.600" 66mm
Jaw Stroke ²	.250" 6.3mm	.250" 6.3mm	.380" 9.6mm	.380" 9.6mm
Actuator Stroke	.710" 18.0mm	.710" 18.0mm	.710" 18.0mm	.710" 18.0mm
Max Draw Bar Force	7,100 lbs 31.6 kN	4,730 lbs 21.0 kN	7,100 lbs 31.6 kN	4,730 lbs 21.0 kN
Min Draw Bar Force	600 lbs 2.7 kN	600 lbs 2.7 kN	600 lbs 2.7 kN	600 lbs 2.7 kN
Max Clamping Force ³	16,330 lbs 72.6 kN	10,875 lbs 48.4 kN	12,780 lbs 56.8 kN	8,515 lbs 37.9 kN
Max Speed ⁴	3,500 rpm	3,500 rpm	2,500 rpm	2,500 rpm
Chuck Weight ⁵	74.2 lbs 33.7 kg	74.2 lbs 33.7 kg	74.2 lbs 33.7 kg	74.2 lbs 33.7 kg
Moment of Inertia ⁵	7.03 lb-ft ² 0.30 kg-m ²	7.03 lb-ft ² 0.30 kg-m ²	7.03 lb-ft ² 0.30 kg-m ²	7.03 lb-ft ² 0.30 kg-m ²

1 - Accuracy is the total indicator reading (radial and lateral runout) of a master gage measured 1.00" (25.4mm) from the top face of the standard top jaw at 1/2 max draw tube force.

2 - Total jaw stroke.

3 - Total clamping force.

4 - Maximum speed with standard top jaw at max draw tube force.

5 - Without top jaws and spindle mounting plate.

Standard Accessories

- Blank draw tube adapter
- Blank top jaws, chuck lubricant, and grease guns are sold separately. See pages 13 and 14 for available accessories.

Threaded Draw Tube Adapters & Spindle Mounting Plates

- Threaded draw tube adapters are furnished on request
- A2-6, A2-8 as well as other spindle mounting plates are available on request.

PPC250D/QC Dimensions

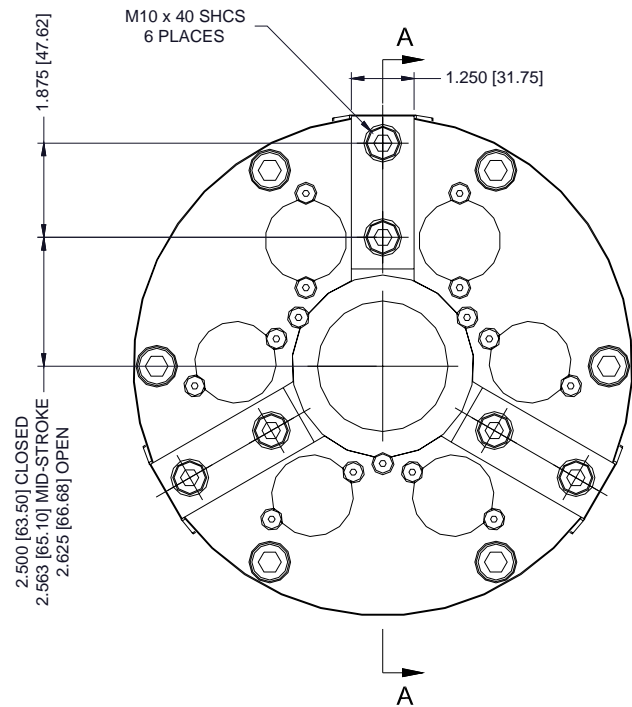
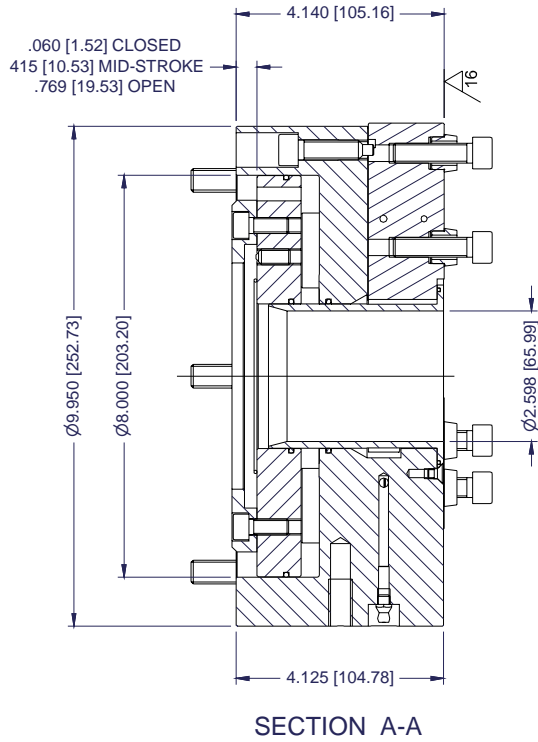

PPC250D/QC/A8 Dimensions

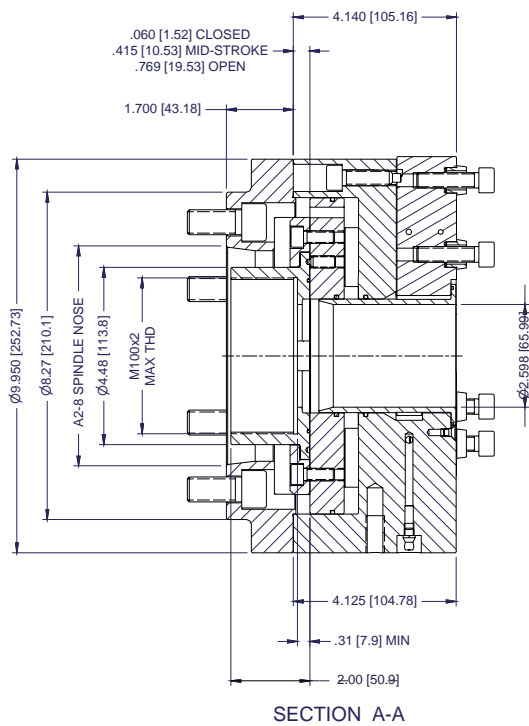

PPC250D/QC/A6 Dimensions

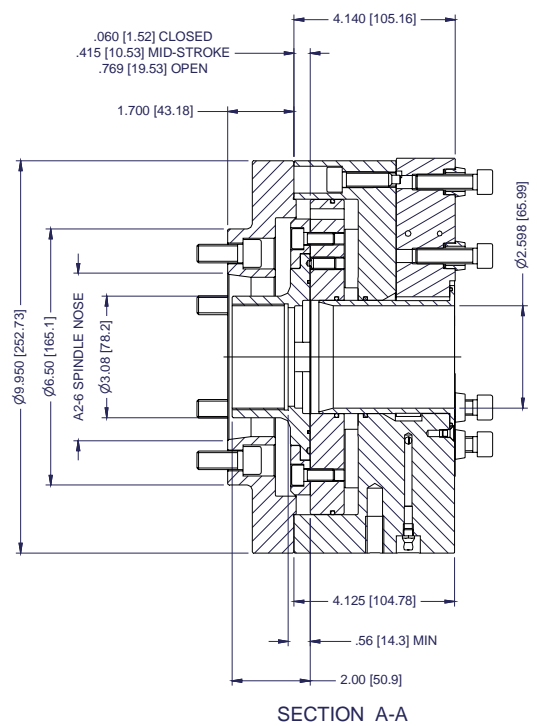

PPC300D106 Models



Features

- 12.00" (300mm) chuck diameter
- 3 jaw and 2 jaw models
- QC precision change jaw system
- Standard and long stroke models
- 4.17" (106mm) through hole
- Precision fit master jaws to minimize jaw lift
- Hardened chuck body, actuators, and master jaws, for long term accuracy and performance

Repeating Accuracy

- .0002" (0.005mm) TIR

PPC300D106 Specifications

Chuck Model	PPC300D106-3/QC	PPC300D106-2/QC	PPC300DL106-3/QC	PPC300DL106-2/QC
Accuracy ¹	.0002" 0.005mm	.0002" 0.005mm	.0002" 0.005mm	.0002" 0.005mm
Number of Jaws	3	2	3	2
Through Hole	4.170" 106mm	4.170" 106mm	4.170" 106mm	4.170" 106mm
Jaw Stroke ²	.250" 6.3mm	.250" 6.3mm	.380" 9.6mm	.380" 9.6mm
Actuator Stroke	.710" 18.0mm	.710" 18.0mm	.710" 18.0mm	.710" 18.0mm
Max Draw Bar Force	8,270 lbs 36.8 kN	5,510 lbs 24.5 kN	8,270 lbs 36.8 kN	5,510 lbs 24.5 kN
Min Draw Bar Force	750 lbs 3.3 kN	750 lbs 3.3 kN	750 lbs 3.3 kN	750 lbs 3.3 kN
Max Clamping Force ³	21,580 lbs 95.9 kN	14,240 lbs 63.6 kN	16,830 lbs 74.9 kN	11,110 lbs 49.4 kN
Max Speed ⁴	2,800 rpm	2,800 rpm	2,000 rpm	2,000 rpm
Chuck Weight ⁵	100.8 lbs 45.7 kg	100.8 lbs 45.7 kg	100.8 lbs 45.7 kg	100.8 lbs 45.7 kg
Moment of Inertia ⁵	14.5 lb-ft ² 0.61 kg-m ²	14.5 lb-ft ² 0.61 kg-m ²	14.5 lb-ft ² 0.61 kg-m ²	14.5 lb-ft ² 0.61 kg-m ²

1 - Accuracy is the total indicator reading (radial and lateral runout) of a master gage measured 1.00" (25.4mm) from the top face of the standard top jaw at 1/2 max draw tube force.

2 - Total jaw stroke.

3 - Total clamping force.

4 - Maximum speed with standard top jaw at max draw tube force.

5 - Without top jaws and spindle mounting plate.

Standard Accessories

- Blank draw tube adapter
- Blank top jaws, chuck lubricant, and grease guns are sold separately. See pages 13 and 14 for available accessories.

Threaded Draw Tube Adapters & Spindle Mounting Plates

- Threaded draw tube adapters are furnished on request
- A2-8, A2-11 as well as other spindle mounting plates are available on request.

PPC300D106 Dimensions

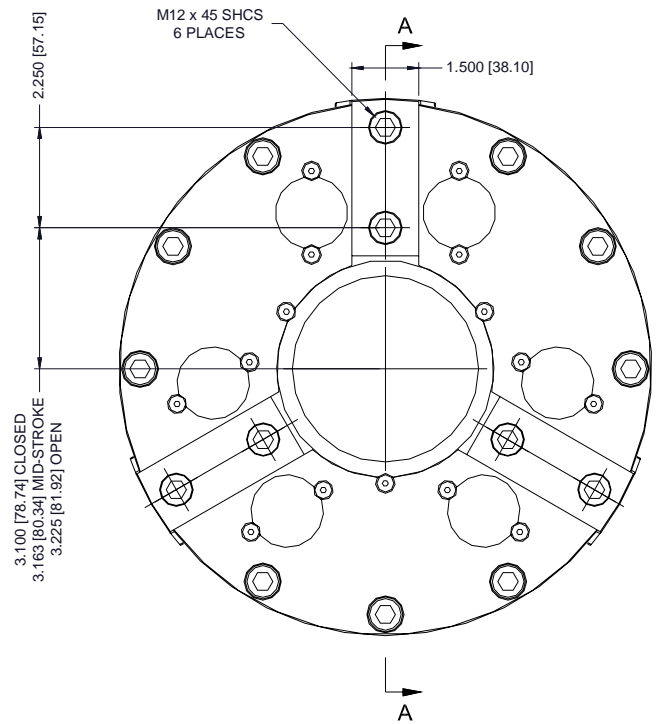
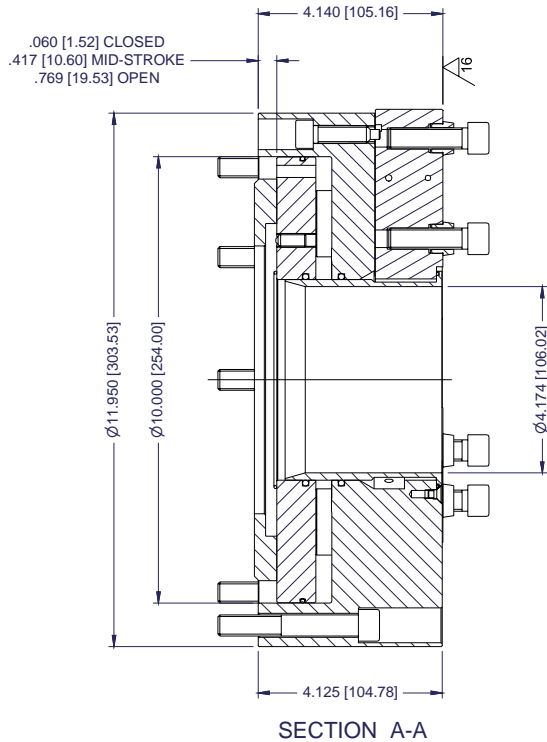

PPC300D106/A8 Dimensions

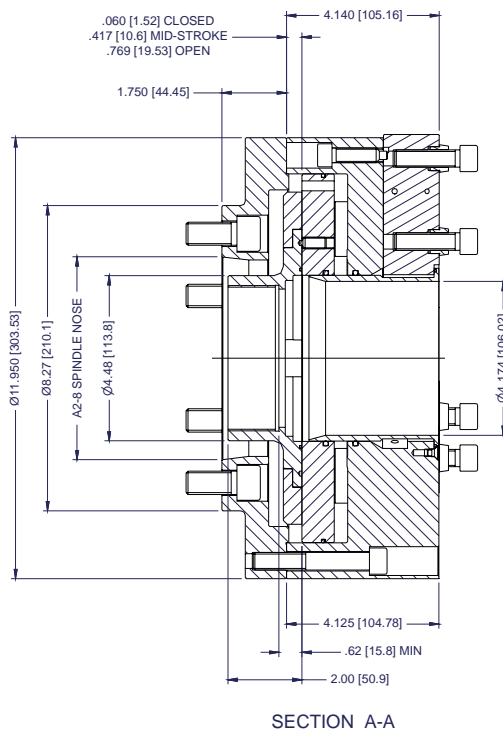

PPC300D106/A11 Dimensions

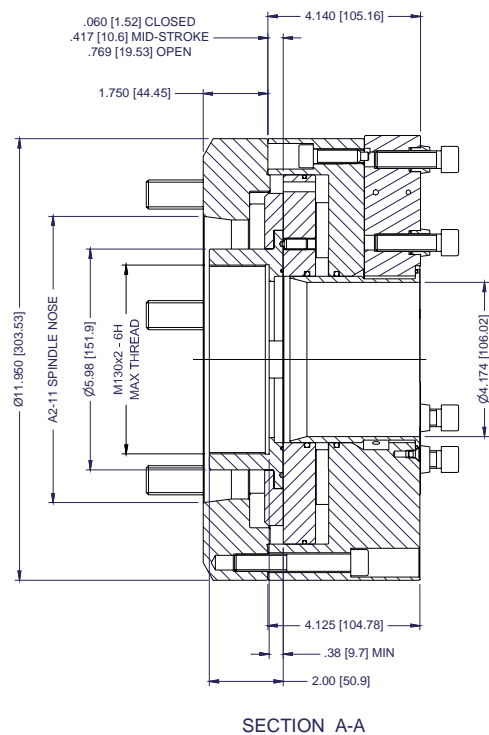

Blank QC Top Jaws

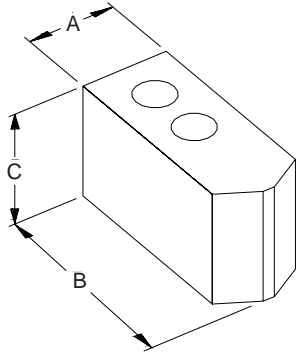

Chuck	Jaw Model	Matl.	A	B	C	Weight*
PPC110	QP4-150S	A-2	.75"	2.12"	1.50"	.59 lb
	QP4-200S	A-2	.75"	2.12"	2.00"	.78 lb
		A-2	19mm	54mm	38mm	.35 kg
PPC165	QP6-200S	A-2	1.25"	3.22"	2.00"	1.8 lb
		A-2	32mm	82mm	50mm	.82 kg
	QP6-300S	A-2	1.25"	3.22"	3.00"	2.7 lb
PPC210	QP8-200S	A-2	1.50"	4.00"	2.00"	2.9 lb
		A-2	38	102mm	50mm	1.3 kg
	QP8-300S	A-2	1.50"	4.00"	3.00"	4.4 lb
PPC250	QP10-200S	A-2	1.50"	4.88"	2.00"	3.7 lb
		A-2	38mm	124mm	50mm	1.7 kg
	QP10-300S	A-2	1.50"	4.88"	3.00"	5.5 lb
PPC300	QP12-200S	A-2	1.50"	5.88"	2.00"	6.0 lb
		A-2	38mm	149mm	50mm	2.7 kg
	QP12-300S	A-2	1.50"	5.88"	3.00"	9.0 lb
		A-2	38mm	149mm	76mm	4.1 kg

*Weights are per piece

Blank QC Top Jaws are made from A-2 tool steel. The tapered locating holes are precision jig bored for accurate location. QC jaws can be heat treated with minimal distortion to a hardness up to Rc 62.

Special QC Top Jaws including blank pie-shaped jaws are quoted upon request.

QC Jaw Turning Fixtures

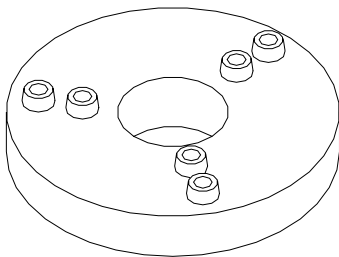

Chuck	Turning Fixture Model
PPC110D-3/QC	QC/JTF-P110D-3
PPC110D-2/QC	QC/JTF-P110D-2
PPC110D-3/DP	DP/JTF-P110D-3
PPC110D-2/DP	DP/JTF-P110D-2
PPC165D-3/QC	QC/JTF-P110D-3
PPC165D-2/QC	QC/JTF-P165D-2
PPC210D-3/QC	QC/JTF-P210D-3
PPC210D-2/QC	QC/JTF-P210D-2
PPC250D-3/QC	QC/JTF-P250D-3
PPC250D-2/QC	QC/JTF-P250D-2
PPC300D106-3/QC	QC/JTF-P300D-3
PPC300D106-2/QC	QC/JTF-P300D-2

QC jaw turning fixtures simulate the locating pattern of a QC chuck. They are used to rough machine Blank QC Top Jaws *off-line* to maximize a machine's production capacity. The clamping position of the jaw turning fixture is set in the middle of the chuck's stroke. Other positions are available upon request.

Chuck Lubricant



<i>Model</i>	<i>Quantity</i>	<i>Manufacturer</i>
ALTEMP Q NB 50/080	80 gram tube	Kluber
ALTEMP Q NB 50/600	600 gram cartridge	Kluber
ALTEMP Q NB 50/750	750 gram cartridge	Kluber

Kluber ALTEMP Q NB 50 is the recommended lubricant for PPC chucks. ALTEMP Q NB 50 is a white lubricating paste containing a mineral base oil, a barium complex soap and inorganic solid lubricants. This lubricant has been found to improve the sliding characteristics of moving chuck components and enabling constant clamping force. It prevents stick-slip and protects against fretting and tribo-corrosion in frictional or positive connections. ALTEMP Q NB 50 is resistant to oils and water soluble cutting fluids.

Grease Guns



<i>Model</i>	<i>Capacity</i>	<i>Chuck Model</i>
H-1	6 oz (177 ml)	PPC110
P-1	14 oz (414 ml)	PPC165 and larger

The H-1 is a pump style oil gun with an internal reservoir and includes a tip suited to the grease fittings on PPC110 models.

The P-1 is a lever operated cartridge style grease gun with a tip suited to the fittings on PPC165 and larger chuck models.

Loading Rings



<i>Chuck Size</i>	<i>Model</i>	<i>Application</i>
PPC110	CR-P4	OD Clamping
	LR-P4	ID Clamping
PPC165	CR-P6	OD Clamping
	LR-P6	ID Clamping
PPC210	CR-P8	OD Clamping
	LR-P8	ID Clamping
PPC250	CR-P10	OD Clamping
	LR-P10	ID Clamping
PPC300	CR-P12	OD Clamping
	LR-P12	ID Clamping

Loading rings are used to set the chuck in a clamping position for machining top jaws. CR loading rings are a cam design which provide easy adjustment of the loading position for OD clamping. LR loading rings are used for ID clamping jaws.



MicroCentric Corporation
25 So. Terminal Drive, Plainview, NY 11803-2303 • USA
Tel: 516-349-7220 • Fax: 516-349-9354 • e-mail: sales@MicroCentric.com
1-800-573-1139 • www.microcentric.com

MicroCentric GmbH
Postfach 1337 • Berblinger Str. 16 • 71254 Ditzingen • Germany
Tel: 07156/17819-0 • Fax: 07156/17819-20 • e-mail: info@MicroCentric.de
www.microcentric.de